

# KE-8246

## 3-WAY TYPE BALL VALVES, SCREWED ENDS

MATERIAL: S.S.316, INVESTMENT CASTING

SIZE: 1/4" thru 2"

WORKING PRESSURE: 1000 WOG

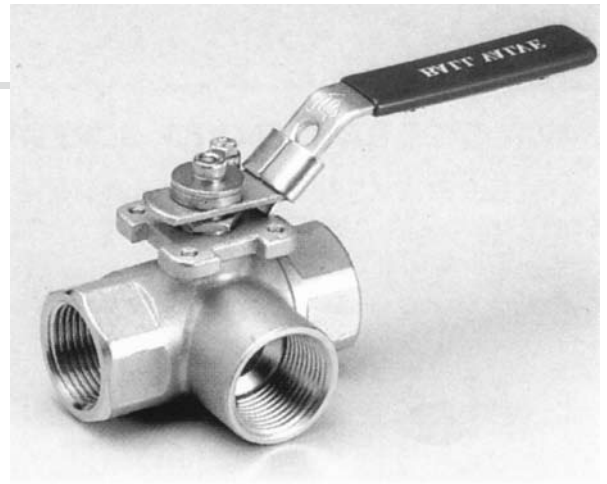

Type	Size	1	2	3	4
L PORT					

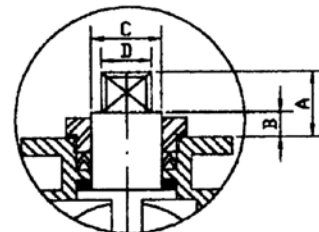
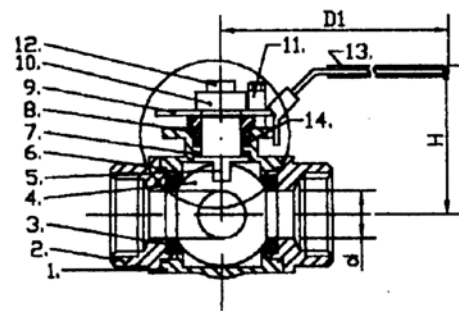
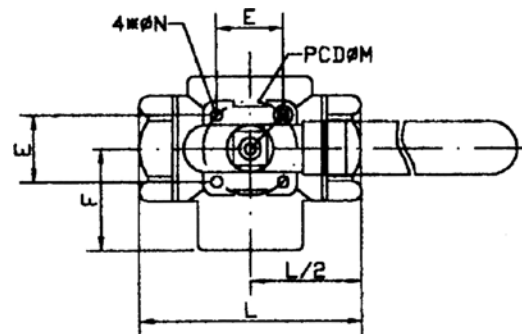

MATERIALS LIST		
NO.	PART NAME	MATERIAL
1	BODY	ASTM A351 GR. CF8M
2	END CAP	ASTM A351 GR. CF8M
3	BALL SEAT	PTFE
4	BALL	ASTM A351 GR. CF8M
5	STEM	S.S. 316
6	END SEALS	PTFE
7	THRUST WASHER	PTFE
8	GLAND	S.S. 304
9	HANDLE	S.S. 304
10	HANDLE WASHER	S.S. 304
11	WASHER	S.S. 304
12	HANDLE NUT	S.S. 304
13	HANDLE SLEEVE	PLASTIC
14	STEM PACKINGS	PTFE

DIMENSIONS												Unit:mm
SIZE	d	L	H	D1	A	B	C	D	E	F	M	N
1/4"	11	58	72	132	10	5	12	9	25	29	36	M5x0.8
3/8"	11	58	72	132	10	5	12	9	25	29	36	M5x0.8
1/2"	12.5	66	72	132	10	5	12	9	25	33.5	36	M5x0.8
3/4"	16	77	79	132	10	5	12	9	25	38.7	36	M5x0.8
1"	20	90	86	132	10	5	12	9	29	46	42	M5x0.8
1-1/4"	25.4	103.5	113	180	18.5	7	15	11	35.5	51.7	50	M6x1
1-1/2"	31.8	110	124	180	18.5	7	15	11	35.5	61	50	M6x1
2"	38.1	137	140	210	18.5	7	15	14	35.5	71.4	50	M6x1