

KE-8247

3-WAY TYPE BALL VALVES, SCREWED ENDS

WITH DIRECT ASSEMBLY ISO 5211 TOP FLANGE
 MATERIAL: S.S.316, INVESTMENT CASTING
 SIZE: 1/4" thru 2"
 WORKING PRESSURE: 1000 WOG



SCREWED ENDS



CLAMP ENDS

Type \ Size	1	2	3	4
L PORT				
T PORT				

MATERIALS LIST		
NO.	PART NAME	MATERIAL
1	BODY	ASTM A351 GR. CF8M
2	END CAP	ASTM A351 GR. CF8M
3	BALL SEAT	REINFORCED PRFE
4	BALL	ASTM A351 GR. CF8M
5	STEM	S.S.316
6	GASKET	PTFE
7	THRUST WASHER	PTFE
8	PACKING	PTFE
9	RING	S.S.304
10	WASHER	S.S.410
11	HANDLE NUT	S.S.304
12	LOCKING PLATE	S.S.304
13	SPRING WASHER	S.S.304
14	END CAP	ASTM A351 GR. CF8M
15	GASKET	PTFE
16	HANDLE SLEEVE	ASTM A194 CF8M

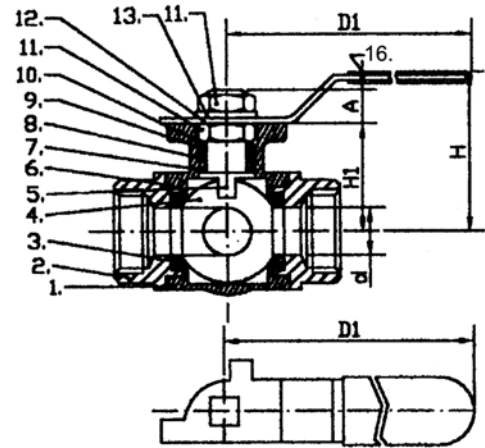
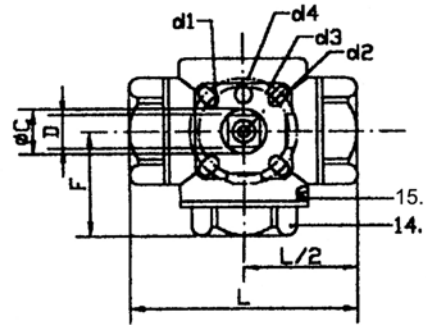

(SCREWED ENDS)													DIMENSIONS		Unit:mm
SIZE	d	L	H	D1	A	C	D	F	d1	d2	d3	d4	H1		
1/4"	11	76	82	112	8	12	9	35.1	6	6	36	42	42		
3/8"	11	76	82	112	8	12	9	35.1	6	6	36	42	42		
1/2"	12.7	76	82	112	8	12	9	38	6	6	36	42	42		
3/4"	16	87	95	112	9	12	9	43.8	6	7.1	36	42	46.5		
1"	20	102	97	136	15.5	15.8	11	50.3	6	7.1	42	50	55		
1-1/4"	25	118	105	188	11.5	15.8	11	57.5	7.1	9.2	42	50	63		
1-1/2"	32	126	122	198	21	20.8	14	64	7.1	9.2	50	70	74		
2"	38.1	149	133	198	15	20.8	14	75.5	9.2	11.4	50	70	88.3		