

# KE-8411

## 1-PC TYPE BALL VALVE, SCREWED ENDS

MATERIAL: S.S. 316/304, C.S. WCB.  
 REDUCED BORE, 800 PSI WOG  
 SIZE: 1/4" THRU 2"

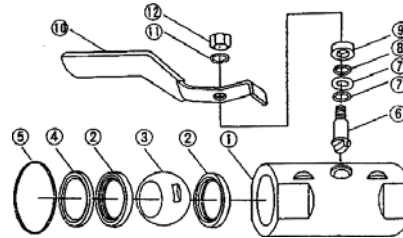

MATERIALS LIST					
NO.	PART NAME	Q'TY	MATERIAL		
1	BODY	1	STEEL	S.S. 316	S.S. 304
2	SEAT	2	TFE	TFE	TFE
3	BALL	1	STEEL	S.S. 316	S.S. 304
4	SEAT RETAINER	1	IRON	S.S. 316	S.S. 304
5	SPIRAL RING	1	S.S. 304	S.S. 316	S.S. 304
6	STEM	1	STEEL	S.S. 316	S.S. 304
7	SEAL	2	RPTFE	RPTFE	RPTFE
8	WASHER	1	S.S. 304	S.S. 316	S.S. 304
9	GRAND RING	1	C.S.	S.S. 304	S.S. 304
10	HANDLE	1	STEEL	STEEL	STEEL
11	SPRING WASHER	1	STEEL	STEEL	STEEL
12	FLEXLOC NUT	1	STEEL	STEEL	STEEL

DIMENSIONS				
	Unit:mm			
SIZE	d	L	H	ℓ
1/4"	9.5	57	28	116
3/8"	9.5	57	28	116
1/2"	9.5	60	32	116
3/4"	12.5	67	38	116
1"	17	76	45	116
1 1/4"	22.2	90	55	150
1 1/2"	25	98	60	155
2"	32	112	75	185

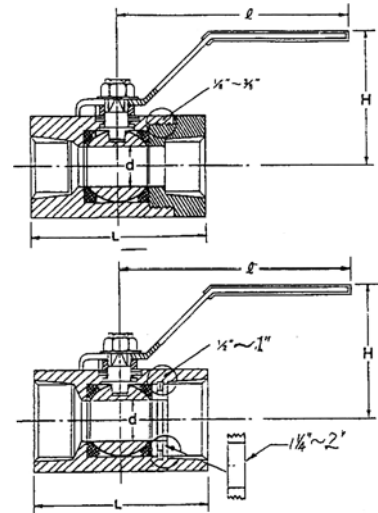

# KE-8412

## 1-PC TYPE BALL VALVE, SCREWED ENDS

MATERIAL: S.S. 316, INVESTMENT CASTING  
 REDUCED BORE, 1000 PSI WOG  
 SIZE: 1/4" THRU 2"

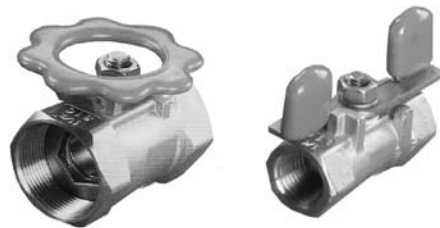

MATERIALS LIST			
No.	PART NAME	Q'TY	MATERIAL
1	STEM	1	316
2	STEM NUT	1	304
3	STEM WASHER	1	304
4	HANDLE	1	304
5	COVER	1	PLASTIC
6	DISC	1	304
7	STEM PACKING	1	PTFE
8	THRUST WASHER	1	PTFE
9	BALL	1	316
10	SEAT	2	PTFE
11	BODY	1	316
12	IN SCREWED PART	1	316

DIMENSIONS				
	Unit:mm			
SIZE	D	L	H	R
1/4"	7	39	30	63
3/8"	7	44	32	70
1/2"	9.2	57	38	85
3/4"	13	60	40	85
1"	15	72	45	100
1-1/4"	20	78	50	106
1-1/2"	25	84	58	128
2"	32	99	65	128

