

# KE-8413

## 1-PC HEX. TYPE BALL VALVES, SCREWED ENDS

MATERIAL: S.S. 316, POLISHED BODY,  
INVESTMENT CASTING  
REDUCED BORE, 800 PSI WOG  
SIZE: 1/4" THRU 2"

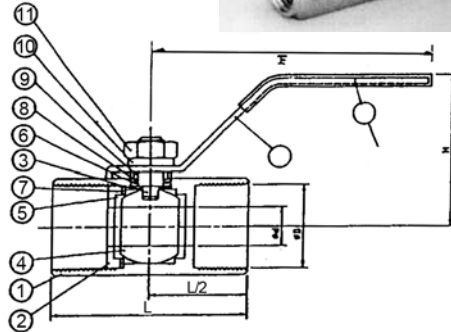

MATERIALS LIST		
No.	PART NAME	MATERIAL
1	BODY	ASTM A351 GR. CF8M
2	INSCREWED SEAT RETAINER	SS316
3	STEM	SS316
4	BALL	ASTM A351 GR. CF8M
5	BALL SEAT	PTFE
6	THRUST WASHER	PTFE
7	CAP SEAT	PTFE
8	PACKING	PTFE
9	GLAND	SS304
10	WASHER	SS304
11	HANDLE NUT	SS304
12	HANDLE	SS304
13	HANDLE SLEEVE	VINYLGRIP

DIMENSIONS					
SIZE	$\phi d$	D	H	E	L
1/4"	5.0	18	30	60	41
3/8"	7.0	22	30	80	47
1/2"	9.0	26	54	90	58
3/4"	12.5	32	66	100	65
1"	15.0	37	68	110	77
1-1/4"	20.0	47	71	110	90
1-1/2"	25.0	55	75	130	98
2"	32.0	67	80	130	110

# KE-8414

## 1-PC HEX. TYPE BALL VALVES, SCREWED ENDS

MATERIAL: S.S. 316, INVESTMENT CASTING  
REDUCED BORE, 800 PSI WOG  
SIZE: 1/4" THRU 2"

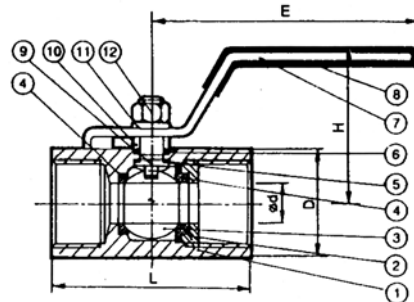

MATERIALS LIST			
No.	PART NAME	QTY	MATERIAL
1	BODY	1	AISI 316
2	CAP	1	AISI 316
3	BALL	1	AISI 316
4	SEAT	2	PTFE
5	THRUST WASHER	1	PTFE
6	STEM PACKING	1	PTFE
7	HANDLE	1	AISI 304
8	PLASTIC COVER	1	PLASTIC
9	STEM	1	AISI 316
10	GLAND	1	AISI 304
11	STEM WASHER	1	AISI 304
12	STEM NUT	1	AISI 304

DIMENSIONS					
SIZE	$\phi d$	D	H	E	L
1/4"	5.0	10.5	30	60	41
3/8"	7.0	21	30	80	47
1/2"	10.0	25	54	90	57
3/4"	13.0	32	58	90	64
1"	16.0	38	68	110	74
1-1/4"	20.0	48	71	150	88
1-1/2"	25.0	55	75	150	97
2"	32.0	68	80	150	108