

# KE-8415

## 1-PC HEXAGONAL TYPE BALL VALVES, SCREWED ENDS

MATERIAL: C.S. WCB  
 REDUCED BORE, 2000 PSI WOG  
 SIZE: 1/4" thru 2"



MATERIALS LIST		
No.	PART NAME	MATERIAL
1	BODY	CARBON STEEL
2	INSCREWED SEAT RETAINER	CARBON STEEL
3	STEM	SS 304
4	BALL	SS 304
5	BALL SEAT	PTFE
6	THRUST WASHER	PTFE
7	CAP SEAT	PTFE
8	PACKING	PTFE
9	GLAND	CARBON STEEL
10	WASHER	CARBON STEEL
11	HANDLE NUT	CARBON STEEL
12	HANDLE	CARBON STEEL
13	HANDLE SLEEVE	VINYL GRIP
14	GLAND NUT	CARBON STEEL

DIMENSIONS						
SIZE	φ d	D	H	E	L	
1/4"	5.0	19	30	80	41	
3/8"	7.0	23	30	80	47	
1/2"	9.0	29	54	90	58	
3/4"	12.5	35	66	100	65	
1"	15.0	41	68	110	77	
1-1/4"	20.0	54	71	110	90	
1-1/2"	25.0	58	75	130	98	
2"	32.0	73	80	130	110	

Unit:mm

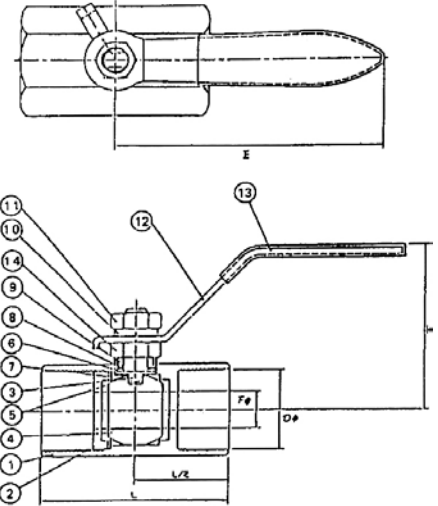

# KE-8416

## 1-PC TYPE BALL VALVES, SCREWED ENDS

MATERIAL: S.S. 316 & C.S. WCB  
 INVESTMENT CASTING, 2000 PSI WOG  
 SIZE: 1/4" thru 3/8" (FULL PORT),  
 1/2" thru 2" (REDUCED BORE)



DIMENSIONS							
SIZE	1/4"	3/8"	1/2"	3/4"	1"	1-1/4"	1-1/2"
A	9.2	9.2	9.2	12.5	15	20	25
B	58	58	66	72	82	90	98
C	43	43	43	46	58	64	72
D	110	110	110	110	146	146	188
E	29	29	29	29	35	35	45
F	9.5	9.5	9.5	9.5	12.2	12.2	16.5

TEST PRESSURE 1/4"~2"	
SHELL TEST(WATER)	3000PSI
SHELL TEST(WATER)	2200PSI
SHELL TEST(AIR)	80PSI

MATERIALS LIST			
No.	PART NAME	MATERIAL	
1	BODY	CF8M	WCB
2	SPACER	CF8M	WCB
3	BALL	CF8M	
4	BALL SEAT	PTFE+15%GF	
5	SPACER SEAL	PTFE+15%GF	
6	THRUST WASHER	PTFE+15%GF	
7	STEM	AISI 316	
8	STEM PACKING	GRAPHITE	
9	DISC WASHER	AISI 304	
10	STEM RING	AISI 304	
11	HANDLE	AISI 304	
12	STEM NUT	AISI 304	
13	HANDLE COVER	PLASTIC	

