

# KE-8417

## 1-PC TYPE BALL VALVES, SCREWED ENDS WITH MOUNTING PAD

MATERIAL: S.S. 316 (INVESTMENT CASTING)  
 REDUCED PORT, 800 WOG  
 SIZE: 1/2" thru 2"

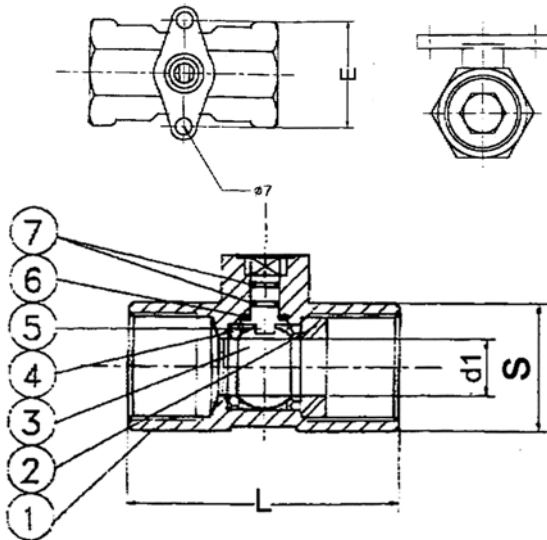

MATERIALS LIST			
No.	PART NAME	Q'TY	MATERIAL
1	BODY	1	SUS 316
2	CAP	1	SUS316
3	BALL	1	SUS 316
4	SEAT	1	PTFE
5	THRUST WASHER	1	PTFE
6	STEM	1	SUS 316
7	O-RING	2	VITON

DIMENSIONS						
Unit:mm						
SIZE	d1	L	H	E	S	
1/2"	9.2	56.5	21.5	38	25	
3/4"	12.5	59	28.5	38	32	
1"	15	71	32.5	38	38	
1-1/4"	20	78	35.5	38	49	
1-1/2"	25	82	42	38	53	
2"	32	100	47.5	38	65	

# KE-8418

## 1-PC TYPE BALL VALVES, SCREWED ENDS

WITH DIRECT ASSEMBLY ISO 5211 TOP FLANGE  
 MATERIAL: S.S. 316 & C.S. WCB INVESTMENT CASTING  
 REDUCED BORE, 1000WOG  
 SIZE: 3/8" thru 2"

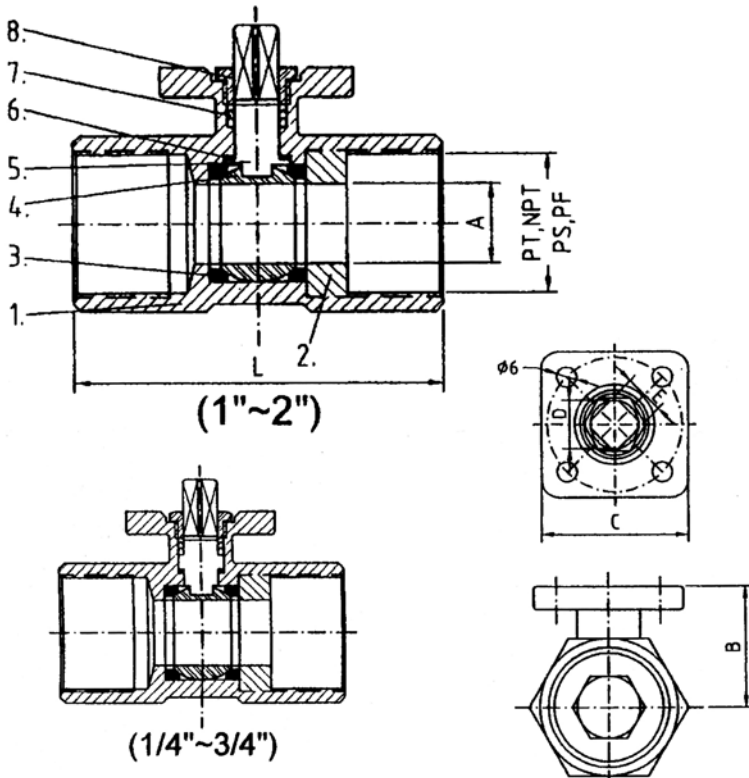

MATERIALS LIST				
NO	PART NAME	Q'TY	MATERIAL	
			316	WCB
1	BODY	1	316/CF8M	S45C/WCB
2	CAP	1	316/CF8M	S45C/WCB
3	SEAT	1	TEFLON	TEFLON
4	BALL	1	316/CF8M	SUS304/316
5	STEM	1	SUS316	SUS304/316
6	GASKET	1	TEFLON	TEFLON
7	SEAL	2	SUS304	SUS304
8	PACKING GLAND	2	SUS301	SUS301

DIMENSIONS							
Unit:mm							
SIZE	A	B	C	D	E	L	ISO 5211
3/8"	7.0	23	36	11	9	45	F03
1/2"	10.0	25	36	11	9	50	F03
3/4"	12.5	32	36	11	9	60	F03
1"	15.0	35	36	11	9	73	F03
1-1/4"	20.0	38	44	14	9	78	F03
1-1/2"	25.0	42	44	14	11	90	F04
2"	32.0	50	44	14	11	100	F04