

KE-8299

BELLOW SEALED VALVES, SOCKET-WELD & BUTT-WELD

MATERIAL: C.S. WCB, S.S.304/S.S.316
 SIZE: 1/2" thru 2"(CLASS 800)
 1/2" thru 12"(ANSI 300)

Fluids:
 Steam, Water, Air, Gas and Oil Systems.



Body Design	CLASS 800	ANSI 300
Max.Op. Temp. (°C)	430	430
Max.Op. Pres. (Barg)	52	52
Hydr. Test (Barg)	150	78(shell)
		58(Disc)
Air Test (Body)	6	6(seat)
for saturated steam system		
Max.Op. Temp. (°C)	270	270
Max.Op. Pres. (Barg)	43	43

DIMENSIONS					Unit:mm
Size	A	B	C	Kv	
15	82	180	110	5.7	
20	95	180	110	10.1	
25	114	190	110	16.3	
40	152	230	130	41	
50	184	240	130	65.5	

Cv(US)-Kvx1.17

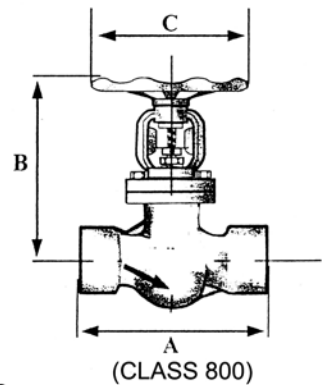

DIMENSIONS					Unit:mm
Size	A	B	C	Kv	
15	152	180	110	4.2	
20	178	180	110	7.5	
25	203	190	110	12	
40	229	230	130	30	
50	267	240	130	48	
65	292	290	180	77	
80	318	320	180	120	
100	356	395	220	188	
125	400	415	220	290	
150	444	465	250	410	
200	559	570	330	725	
250	622	690	380	920	
300	711	840	380	1280	

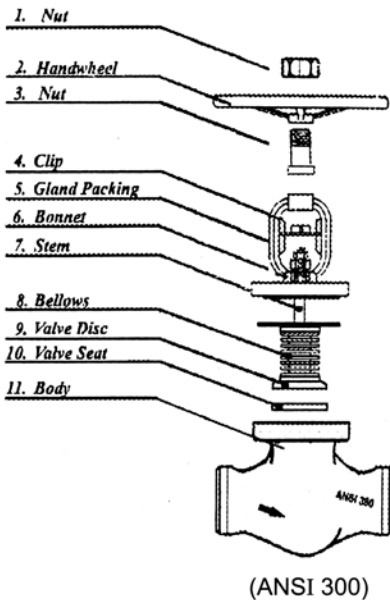
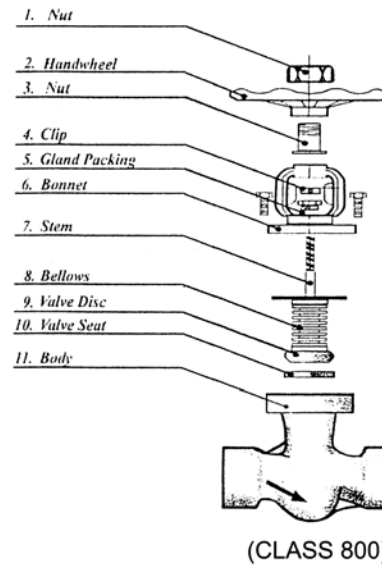
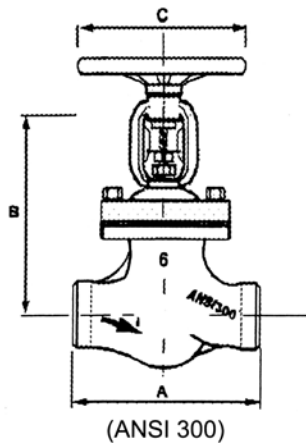

MATERIALS LIST

NO.	PART NAME	MATERIAL		
1	Nut	Steel	Steel	Steel
2	Handwheel	S.S.304	S.S.304	S.S.304
3	Nut	Bronze	Bronze	Bronze
4	Clip	S.S.304	S.S.304	S.S.304
5	Gland Packing	Graphite	Graphite	Graphite
6	Bonnet	Cast Steel	Cast Steel	Cast Steel
7	Stem	S.S.304/316	S.S.304/316	S.S.304/316
8	Bellows	S.S.304/316	S.S.304/316	S.S.304/316
9	Valve Disc	S.S.304/316	S.S.304/316	S.S.304/316
10	Valve Seat	S.S.304/316	S.S.304/316	S.S.304/316
11	Body	Cast Steel	S.S.304	S.S.316