

KE-8814

BUTTERFLY VALVES, WAFER TYPE

MATERIAL: S.S.316 / S.S.304
 FLANGES: ANSI 150LB, JIS 10K
 OPERATION: LEVER HANDLE / WORM GEAR
 SIZE: 2" THRU 18"

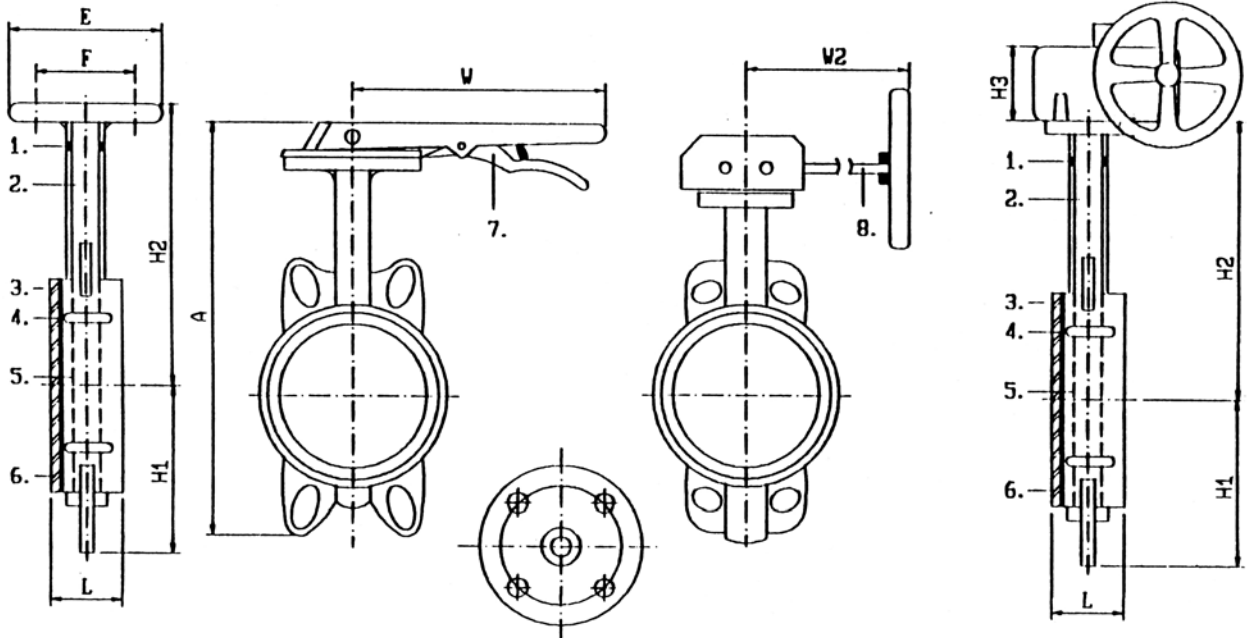
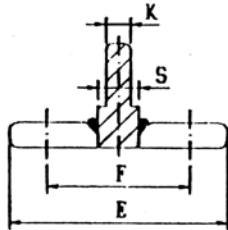

MATERIALS LIST		
NO.	PART NAME	MATERIAL
1	O.RING	N.B.R.
2	SHAFT	SS410, S.S.316/304
3	SEAT	NBR, EPDM, VITON
4	TAPER PIN	S.S.304
5	DISC	S.S.316/304
6	BODY	S.S.316/304
7	HANDLE	FC-20, S.S.304
8	WORM GEAR	FC-20

DIMENSIONS														Unit:mm
SIZE	2"	2-1/2"	3"	4"	5"	6"	8"	10"	12"	14"	16"	18"		
A	200	218	228	296	316	345	404							
L	43	46	46	53	56	56	60	68	78	78	87	106		
W	250	250	250	250	250	345	345							
W2	150	150	150	150	150	215	215	215	225	250	345	345		
H1	55	63	65	113	120	133	161	205	240	270	310	350		
H2	145	156	163	183	196	212	243	288	311	320	390	390		
H3	52	52	52	52	52	60	60	60	60	75	75	80		
F	70	70	70	70	70	70	70	102	102	150	150	150		
E	92	92	92	92	92	92	92	120	120	180	180	180		
S	12.7	12.7	12.7	16	16	19	19	22	28	28	35	35		
K	9	9	9	12.5	12.5	15	15	16	19	19				