

KE-8182A

KNIFE GATE VALVE, PNEUMATIC TYPE

MATERIAL: S.S.316, S.S.316L, S.S.304, C.S.WCB, FC & FCD

CONNECTION RATING

- JIS 5K/10K
- ANSI 150LB
- DIN PN10/PN16

AIR CYLINDER ACCESSORISE

- SOLENOID VALVE
- LIMIT SWITCH
- AIR FILTER REGULATOR LUBRICATOR

PRESSURE TEST:

BODY: 11kg/cm² (WATER)
 PTFE SEAT: 2.8kg/cm² (WATER)
 LEAKAGE ALLOWANCE: 4cc/in.min

TEMPERATURE	
MATERIAL	TEM. RANGE.
ASBESTOS+PTFE	-50° ~ 550°C
SILICON	-20° ~ 150°C
VITON	-20° ~ 250°C
TEFLON	-30° ~ 150°C
NON ASBESTOS	-50° ~ 550°C

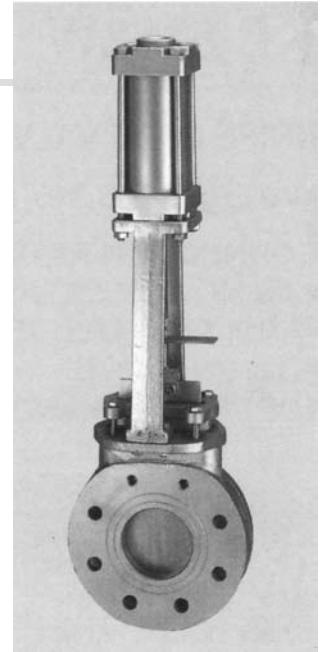

OPERATOR: PNEUMATIC TYPE

WORKING FLUID: DRY AIR
 WORKING TEMPERATURE: -10~80°C
 WORKING PRESSURE: 4~7kg/cm² (AIR)

		MATERIALS LIST					
NO.	PART NAME	MATERIAL					
		304	316	316L	WCB	FC	FCD
1.	BODY	CF8	CF8M	CF3M	WCB	FC	FCD
2.	PLATE	SUS 304/ 316/ 316L			SUS 304		
3.	STEM	SS41+Hcr					
4.	SEAT	TEFLON					
5.	GLAND	SUS 304			CAST IRON		
6.	GLAND PACKING	ASB NON-ASB					
7.	YOKE	DUCTILE IRON					
8.	POINTER	SUS 304					
9.	NUT	SUS 304					
10.	NUT	SUS 304					
11.	CONNECTOR	SUS 304					
12.	BOLT AND NUT	SUS 304					
13.	ACTUATOR	AIALLOY. FC					
14.	GUIDE	SUS 304			CAST IRON		

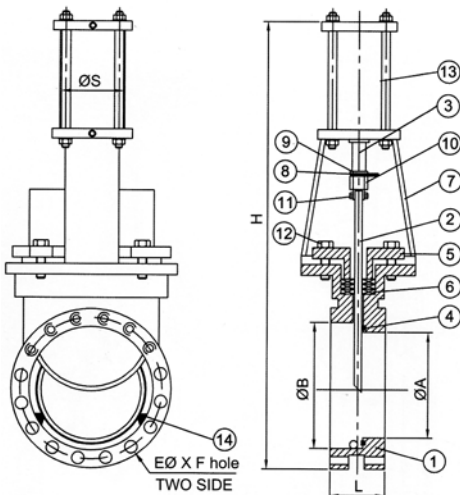

(for C.I. & D.I. VALVE BODY)

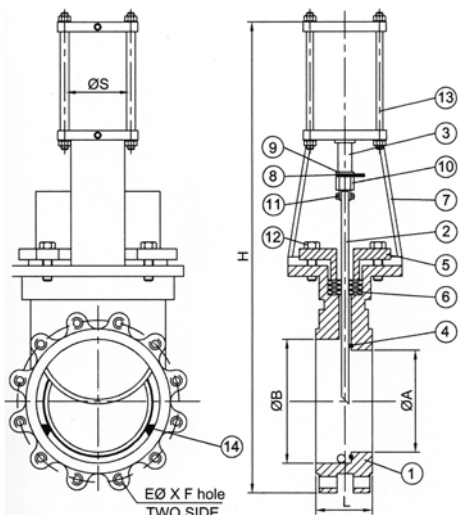

(for S.S. & C.S. VALVE BODY)

		DIMENSIONS							Unit: mm	
SIZE		SS/ CS				FC/ FCD				φ S
		L	φ A	φ B	H	L	φ A	φ B	H	
2"		48	42	64	520	55	42	64	590	63
2-1/2"		51	57	80	570	55	57	80	600	63
3"		51	72	95	680	55	72	95	650	80
4"		51	95	120	755	55	92	114	720	80
5"		57	125	148	900	60	116	141	870	125
6"		57	150	175	960	60	138	161	940	125
8"		70	195	222	1160	70	192	213	1190	150
10"		70	250	275	1440	75	232	261	1440	180
12"		76	300	325	1605	80	280	315	1560	200
14"		76	350	375	1860	80	345	376	1840	250
16"		89	400	430	2070	90	395	425	2060	250
18"		89	435	475	2200	95	445	480	2200	250
20"		114	480	515	2400	120	490	520	2460	300
24"		114	580	620	2750	120	590	630	2750	300