

KE-8281

GATE VALVES, SCREWED ENDS

MATERIAL: CF8M, INVESTMENT CASTING
 SIZE: 1/2" thru 2"
 WORKING PRESSURE: 300(200) PSI

MATERIALS LIST		
No.	PART NAME	MATERIAL
1	BODY	CF8M
2	BONNET	CF8M
3	DISC	CF8M
4	STEM	SS316
5	STEM WASHER	SS316
6	SNAP WASHER	SS316
7	PACKING	TEFLON
8	GLAND	SS316
9	PACKING NUT	CF8M
10	PACKING	TEFLON
11	HANDWHEEL	CAST IRON
12	PLATE	ALUMINUM
13	HANDWHEEL NUT	SS316

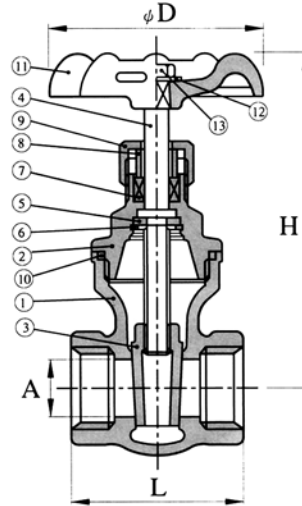

DIMENSIONS					Unit:mm
SIZE	A	L	H	D	
1/2"	15	54	95	60	
3/4"	20	58	105	70	
1"	25	65	115	70	
1-1/4"	32	74	125	80	
1-1/2"	40	78	145	90	
2"	50	87	170	100	

KE-8282

GATE VALVES, SCREWED ENDS

MATERIAL: CF8M, INVESTMENT CASTING
 SIZE: 1/2" thru 2"

MATERIALS LIST			
No.	PART NAME	Q'TY	MATERIAL
1	BODY	1	ASTM A-351GR.CF8M
2	DISC	1	ASTM A-351GR.CF8M
3	STEM	1	SS 316
4	BONNET	1	ASTM A-351GR.CF8M
5	GASKET PACKING	1	TEFLON
6	STEM HOLDER	1	SS 316
7	STEM PACKING	1 SET	TEFLON
8	GLAND	1	SS 304
9	GLAND NUT	1	SS 304
10	HANDLE WHEEL	1	MILD STEEL
11	NAME PLATE	1	ALUMINUM
12	HANDWHEEL WASHER	1	SS 304
13	HANDWHEEL NUT	1	SS 304

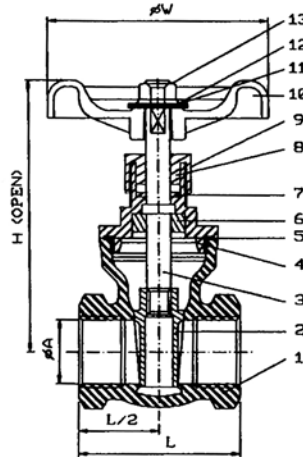

DIMENSIONS					Unit:mm
SIZE	A	H	L	W	
1/2"	15	95	55	70	
3/4"	20	102	60	70	
1"	25	115	65	80	
1-1/4"	32	127	75	80	
1-1/2"	38	150	85	90	
2"	50	170	95	100	