

KE-8194

GLOBE VALVES, FLANGED ENDS

FLANGES: JIS 10K/ 16K/ 20K

MATERIAL: DUCTILE IRON (FCD 45)

SIZE: 1/2" thru 10"

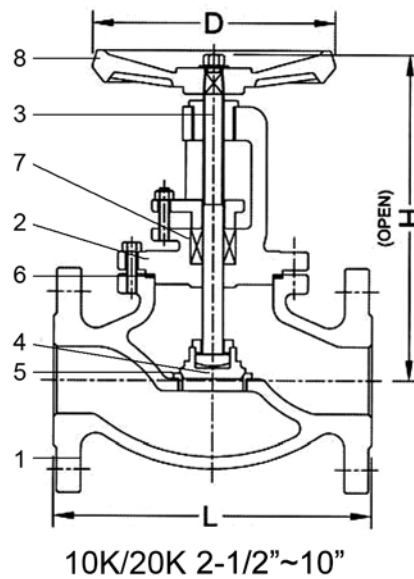
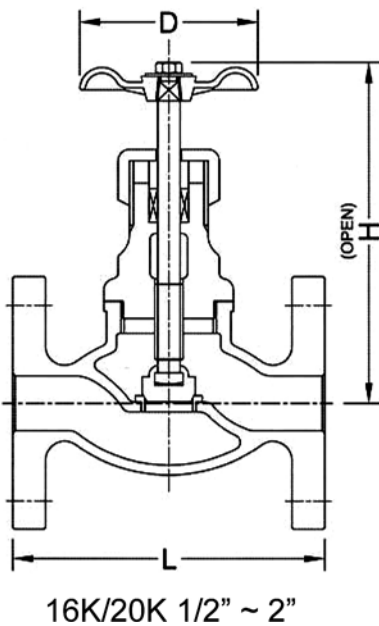
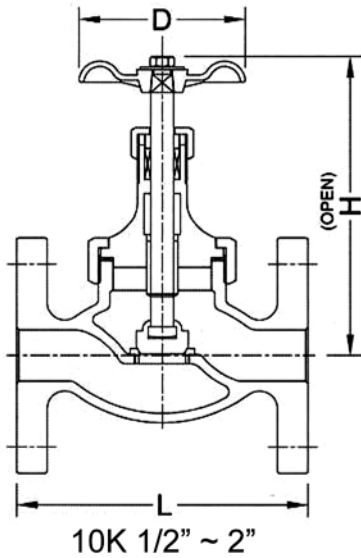

MATERIALS LIST

NO.	PART NAME	MATERIAL
1.	BODY	DUCTILE IRON (FCD 45)
2.	BONNET	DUCTILE IRON (FCD 45)
3.	STEM	STAINLESS STEEL (13Cr)
4.	DISC	STAINLESS STEEL (13Cr)
5.	SEAT RING	STAINLESS STEEL (13Cr)
6.	GASKET	GRAPHITE
7.	PACKING	GRAPHITE
8.	HANDWHEEL	CAST IRON (FC 20)

DIMENSIONS

Unit: mm

SIZE	Inch	1/2"	3/4"	1"	1-1/4"	1-1/2"	2"	2-1/2"	3"	4"	5"	6"	8"	10"
	mm	15	20	25	32	40	50	65	80	100	125	150	200	250
10K	L	108	117	127	140	165	178	216	241	292	356	406	495	622
	H	135	140	165	192	192	200	330	340	395	405	440	570	670
	D	80	80	100	125	125	140	220	220	260	330	330	380	420
16K	L	108	117	127	140	165	203	---	---	---	---	---	---	---
	H	145	145	170	185	205	200	---	---	---	---	---	---	---
	D	80	80	100	125	125	140	---	---	---	---	---	---	---
20K	L	110	120	130	160	180	230	292	318	356	400	444	559	622
	H	150	145	165	180	205	240	345	380	385	450	480	570	670
	D	80	80	100	125	140	180	220	220	260	330	330	380	420