

KE-8295

GLOBE VALVES, SCREWED ENDS

SCREWED-IN BONNET, RISING STEM,
SOLID WEDGE DISC, HANDWHEEL OPERATION
WORKING PRESSURE: 200LB
MATERIAL: S.S. 316 (INVESTMENT CASTING)
SIZE: 1/4" THRU 2"

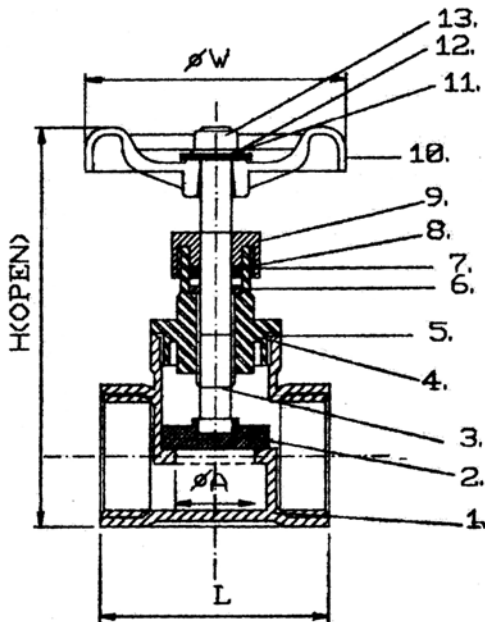

MATERIALS LIST

NO.	PART NAME	Q'TY	MATERIAL
1	BODY	1	ASTM A-351 GR.CF8M
2	DISC	1	SS316
3	STEM	1	SS316
4	BONNET	1	ASTM A-351 GR.CF8M
5	GASKET PACKING	1	TEFLON
6	WASHER	1	SS304
7	STEM PACKING	1 SET	TEFLON
8	GLAND	1	SS304
9	GLAND NUT	1	SS304
10	HANDLE WHEEL	1	MILD STEEL
11	NAME PLATE	1	ALUMINUM
12	HANDLE WHEEL WASHER	1	SS304
13	HANDLE WHEEL NUT	1	SS304

DIMENSIONS

Unit:mm

SIZE	A	H	L	W
1/4"	11	89	52	57
3/8"	11	89	52	57
1/2"	12	89	52	57
3/4"	15	97	60	70
1"	20	107	72	80
1-1/4"	25	125	80	90
1-1/2"	32	140	91	90
2"	38	165	101	100