

KE-8404

EXPANSION JOINT, FLANGED ENDS (FLOATING FLANGE IS AVAILABLE ON REQUEST)

MATERIAL: S.S. 316/ 304
 SIZE: 1-1/2" thru 12"

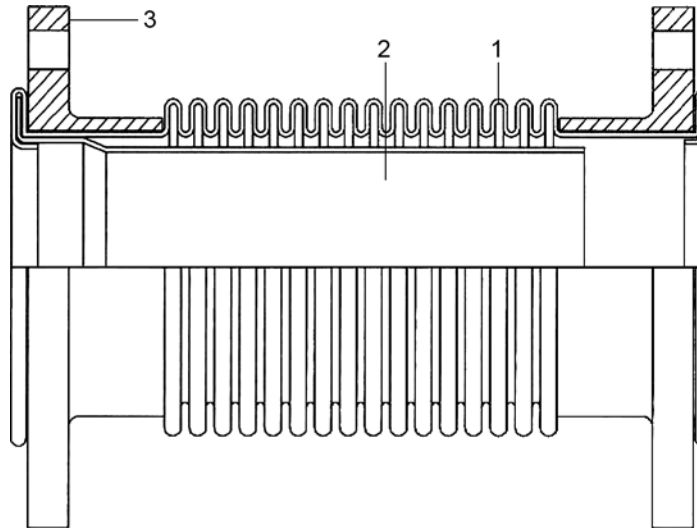

MATERIAL LIST		
ITEM	PARTS	MATERIAL
1	BELLOWS	SUS304/316
2	INTERNAL SLEEVE	SUS304/316
3	FLANGE	FCD400
4	TIE RODS	S25C/SS304

NOMIAL BORE		TOTAL LENGTH		BELLOWS				AXIAL MOVEMENT		WORKING PRESSURE		AXIAL SPREING RATE	EFFECTIVE AREA	
				O.D.		CORR.	PLY							
mm	inch	mm	inch	mm	inch	NO.	NO.	mm	inch	bar	psi	N/mm	cm ²	inch ²
40	1 1/2	300	11.81	58.0	2.36	32	1	50	2	10	145.2	22.44	20.2	3.1
50	2	300	11.81	74.0	3.07	24	1	50	2	10	145.2	18.42	32.8	5.1
65	2 1/2	300	11.81	90.0	3.62	20	1	50	2	10	145.2	45.37	49.6	7.7
80	3	300	11.81	104.0	4.25	20	1	50	2	10	145.2	45.08	67.8	10.5
100	4	300	11.81	130.0	5.20	16	1	50	2	10	145.2	47.82	108.0	16.7
125	5	300	11.81	160.0	6.42	15	1	50	2	10	145.2	84.87	166.5	25.8
150	6	300	11.81	188.0	7.48	14	1	50	2	10	145.2	78.99	232.4	36.0
200	8	300	11.81	242.0	9.57	13	1	50	2	10	145.2	136.42	394.1	61.1
250	10	300	11.81	292.0	11.61	12	1	50	2	10	145.2	179.63	589.7	91.4
300	12	300	11.81	344.0	13.58	12	1	50	2	10	145.2	183.95	829.6	128.6

* Internal sleeve and tie rods are optional.