

KE-8152A

PRESSURE REDUCING VALVE, PRESSURE RELIEF VALVE AND PRESSURE SUSTAINING VALVE

SCREWED & FLANGED ENDS
MATERIAL: S.S. 304/ 316, C.I., D.I. & BRONZE
SIZE: 1-1/2" thru 14"

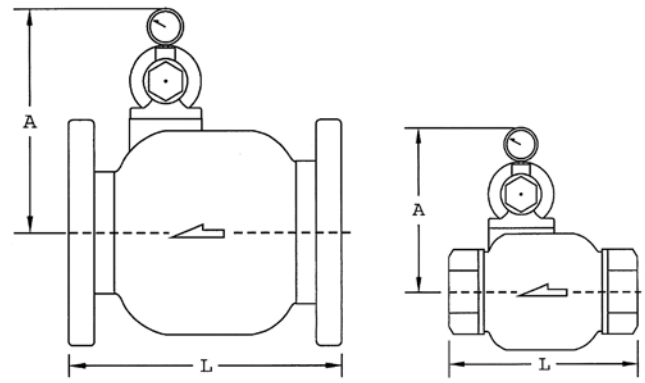
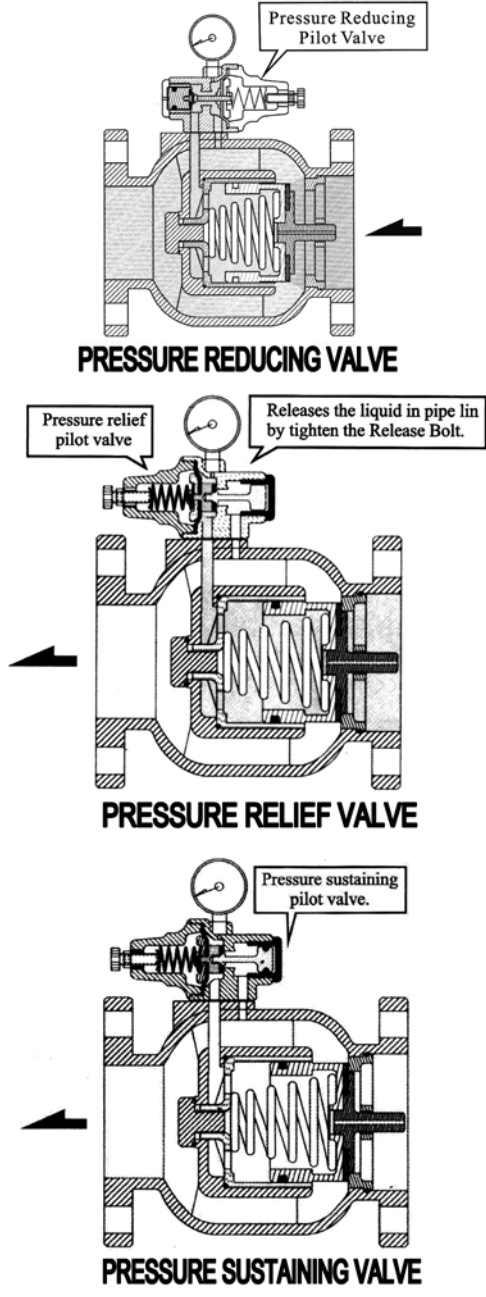

| DIMENSIONS | | | Unit:mm |
|----------------|--------|-----|---------|
| | SIZE | L | A |
| S'CW END | 1-1/2" | 120 | 160 |
| | 2" | 200 | 180 |
| | 3" | 235 | 200 |
| FLANGED END | 2" | 190 | 180 |
| | 2-1/2" | 210 | 185 |
| | 3" | 225 | 200 |
| | 4" | 250 | 222 |
| | 5" | 280 | 235 |
| | 6" | 310 | 260 |
| | 8" | 420 | 300 |
| | 10" | 470 | 335 |
| | 12" | 530 | 370 |
| | 14" | 600 | 415 |

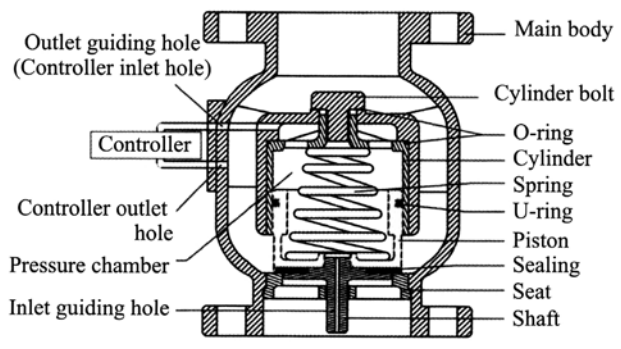

| MATERIALS LIST | | | | |
|----------------|----------------|-----------------|----------------|----------------|
| PART NAME | MATERIAL | | | |
| MAIN BODY | CAST IRON | DUCTILE | BRONZE | STAINLSS STEEL |
| CYLINCLER BOLT | BRASS | BRASS | BRASS | STAINLSS STEEL |
| O-RING | NBR | NBR | NBR | NBR/VITON |
| CYLINCLER | BRONZE | BRONZE | BRONZE | STAINLSS STEEL |
| SPRING | STAINLSS STEEL | STAINLESS STEEL | STAINLSS STEEL | STAINLSS STEEL |
| U-RING | NBR | NBR | NBR | NBR/VITON |
| PISTON | BRONZE | BRONZE | BRONZE | STAINLSS STEEL |
| SEALING | NBR | NBR | NBR | NBR/VITON |
| SEAT | BRONZE | BRONZE | BRONZE | STAINLSS STEEL |
| SHAFT | BRONZE | BRONZE | BRONZE | STAINLSS STEEL |
| CONTROLLER | BRASS | BRASS | BRASS | STAINLSS STEEL |