

# KE-8225

## SAFETY VALVES, SCREWED AND FLANGED ENDS

FLANGES: JIS 10K/ ANSI 150LB  
 MATERIAL: SS304/ SS316  
 SIZE: 1/2" thru 2"  
 HANDLE AND SEALING TYPE

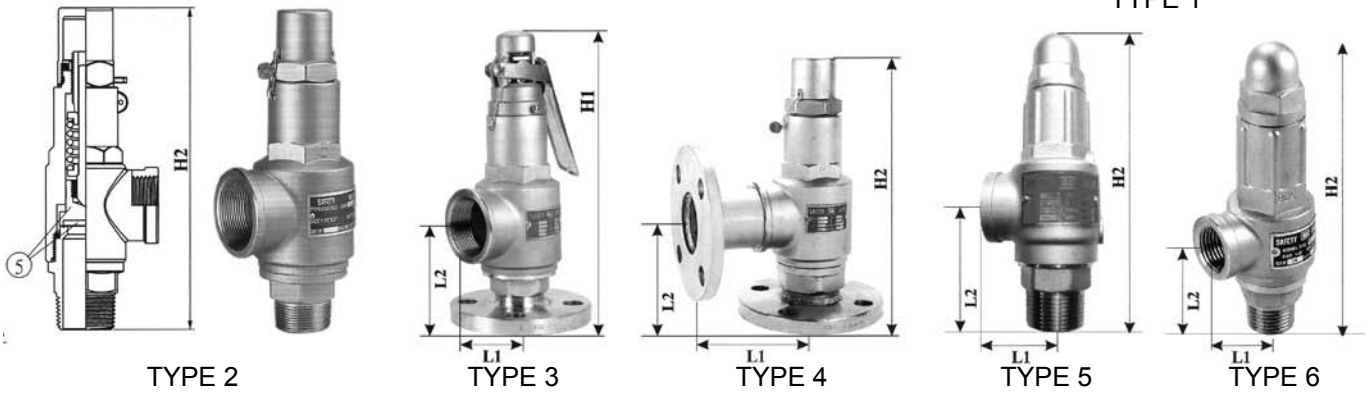
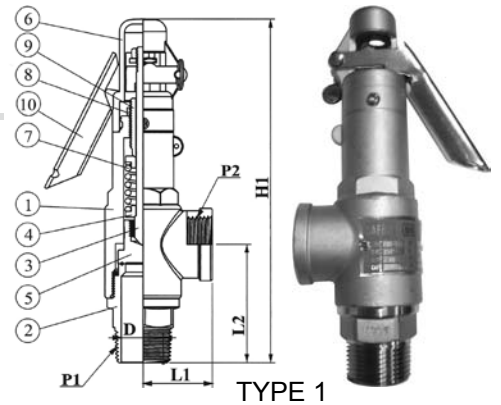

MATERIALS LIST							
NO.	PART NAME	MATERIAL					
		TYPE-1	TYPE-2	TYPE-3	TYPE-4	TYPE-5	TYPE-6
1.	BODY	SS 304/ 316	SS 304/ 316	SS 304/ 316	SS 304/ 316	SS 304	SS 304
2.	SEAT	SS 316		SS 304/ 316		SS316	
3.	SPINDLE	SS 304					
4.	SPRING SEAT	SS 304					
5.	DISC	SS 316	SS 316+ VITON SS 316+EPDM	SS 316	SS 316	SS 316	SS 316
6.	CAP	SS 304					
7.	SPRING	SS 304					
8.	NUT	SS 304					
9.	ADJUST SCREW	SS 304					
10.	HANDLE	SS 304					
Working Pressure (kg/cm <sup>2</sup> )		0.1~110	0.1~50	0.1~110	0.1~110	0.1~25	0.1~20
Working Temp. (deg C)		-196~350	-40~200	-196~350	-196~300	-196~350	-196~350

DIMENSIONAL LIST												UNIT: mm
	D	P1	P2	LIFT	L1	L2	H1	H2				
TYPE1~2	15	1/2	1	1.04	41	66	200	179				
	20	3/4	1	1.52	41	65	199	177				
	21	1	1	2	41	71	205	183				
	33	1-1/4	2	2.56	65	101	285	261				
	39	1-1/2	2	3.04	65	101	285	261				
	39	2	2	4	65	104	288	265				
TYPE3~4	D	P1	P2	LIFT	TYPE-3	TYPE-4	TYPE-3	TYPE-4	TYPE-3	TYPE-4	TYPE-3	TYPE-4
	15	1/2	1/2	1.04	41	84.5	66	72	200	203	179	182
	20	3/4	3/4	1.52	41	--	72	72	--	203	183	--
	20	3/4	1	1.52	41	84.5	72	--	199	--	--	182
	21	1	1	2	41	99	77	77	205	210	183	187
	33	1-1/4	1-1/4	2.56	65	128	101	106	285	289	261	265
TYPE5	D	P1	P2	LIFT	L1	L2	H1	H2				
	15	1/2	1	3	40	60.5	194.5	168.5				
	20	3/4	1	3	40	60	194	168				
	25	1	1	3	40	65.5	199.5	173.5				
	32	1-1/4	2	6	66	92	282.9	256.4				
	40	1-1/2	2	6	66	92.5	283.4	256.9				
TYPE6A	13	1/2	1/2	3	31	46.96	---	134.1				
TYPE6B	13	1/2	1/2	3	31	32.26	---	119.4				

H1: LEVER TYPE, H2: SEALING TYPE, TYPE6A: male x female, TYPE6B: female x female