

KE-8153 & KE-8154

AIR VENT

MATERIAL: CAST IRON, S.S.316/ 304
 SIZE: 1/2" thru 1"
 MOP: 34 kg/cm²
 TEMPERATURE: 90°C
 MAX. DISCHARGE CAPACITY: 18.5 kg/hr



KE-8153

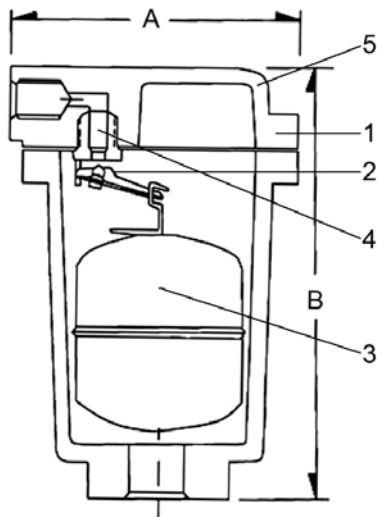

KE-8154

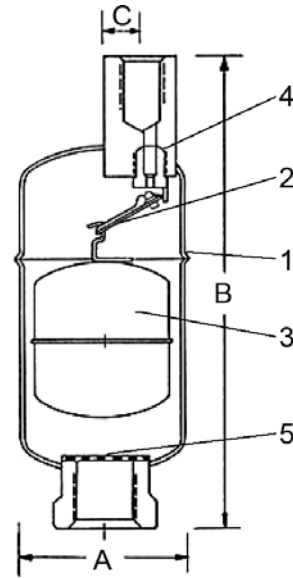

MATERIAL LIST (KE-8153)		
NO.	PART NAME	MATERIAL
1	BODY	ASTM 48, CLASS 30, CAST IRON
2	MECIANISM	S.S. 304
3	FLOAT	S.S. 304
4	VELVE AND SEAT	S.S. 440 HARDENED
5	BOLTS & NUTS	CARBON STEEL

MATERIAL LIST (KE-8154)		
NO.	PART NAME	MATERIAL
1	BODY	S.S 304L OR 316
2	MECHANISM	STAINLESS STEEL
3	FLOAT	STAINLESS STEEL
4	SEAT & VALVE	S.S.440C HARDNED
5	STRAINER	STAINLESS STEEL

DIMENSION LIST						
NO.	CONN.SE.	A	B	C	MOP	WT
KE-8153	15.20.25	80	135	----	21Kx90°C	2
KE-8154	15.20.25	70	188	14	34Kx38°C	1

CONTINUOUS DISCHARGE CAPACITY OF CONDENSATION IN KG/HR	
PRESSURE	
1K	1.71
2K	2.40
3K	4.80
10K	9.50
15K	14.00
21K	18.50

MINMUM GRAVITY.	0.75	0.5
ORIFICE(mm)	MOP	
3.1 Ø	12	8
2.5 Ø	18	12
1.9 Ø	28	21