

KE-8161

STEAM TRAP, FLANGED ENDS

MATERIAL: C.I. FC-20, SAND CASTING
 SIZE: 1/2" thru 2"

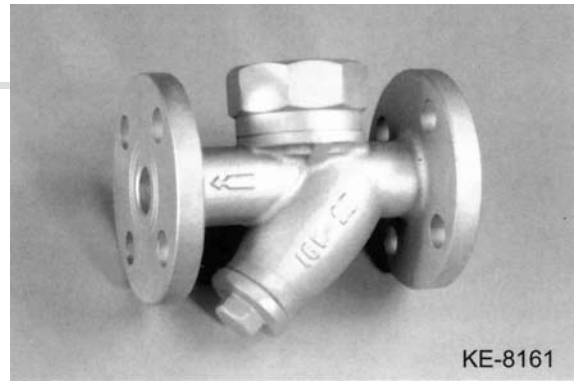

KE-8161

KE-8261

STEAM TRAP, SCREWED ENDS

MATERIAL: C.I. FC-20, SAND CASTING
 SIZE: 1/2" thru 2"

- WORKING PRESSURE : 5 TO 230 PSI.
- MAX. WORKING TEMPERATURE : 220°C
- TEST PRESSURE : BODY 350 PSI (WATER)

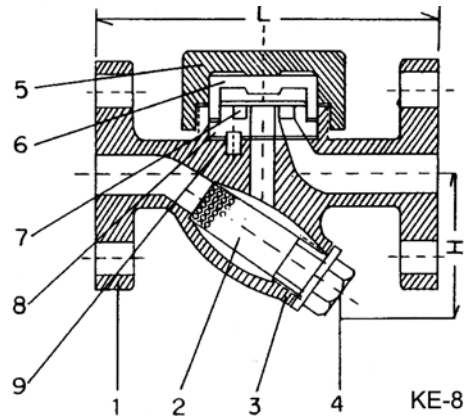

KE-8161

MATERIALS LIST		
NO.	PART NAME	CAST IRON
1	BODY	FC-20
2	SCREEN	SUS 304
3	WASHER	ASBESTOS
4	NUT	FC-20
5	BONNET	FC-20
6	NUT	FC-20
7	DISC	AISI 420
8	DRAIN PLUG	SUS 304
9	WASHER	ASBESTOS

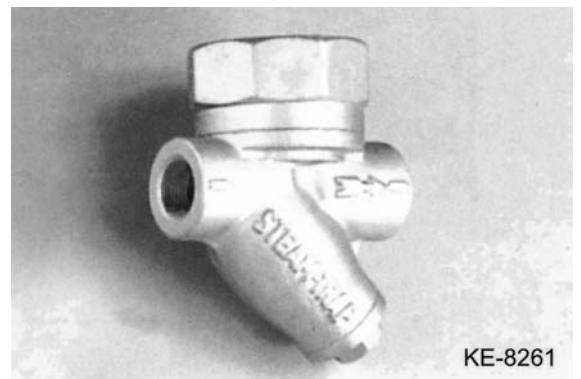

KE-8261

DIMENSIONS							
Unit:mm							
SIZE	Inch	1/2"	3/4"	1"	1 1/4"	1 1/2"	2"
	mm	15	20	25	32	40	50
KE-8161							
L		145	163	170	205	205	240
H		68	75	87	110	110	115
KE-8261							
L		98	105	115	173	173	203
H		68	75	88	115	115	120

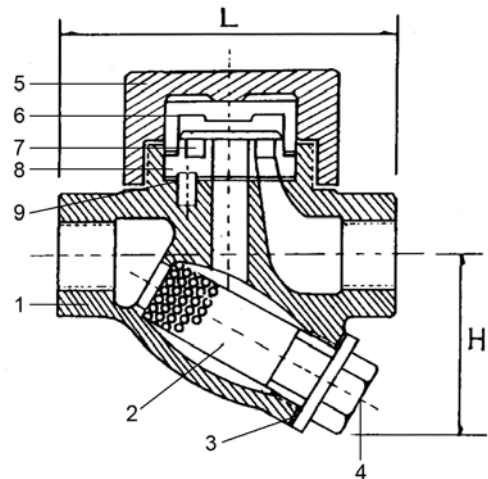

KE-8261

REMARKS:

1. FOR 1/2" TO 1" ARE OCTAGONAL;
 FOR 1-1/4" TO 2" ARE TETRAGONAL AND BOLTED.
2. DIMENSIONS OF FLANGE CONFORMS TO JIS10K OR ANSI 150LB SPECIFICATIONS.