

KE-8171

STEAM TRAP, FLANGED ENDS(WITH HANDWHEEL)

MATERIAL: CAST IRON

SIZE: 1/2" thru 2"

- TEST PRESSURE: 16 kgf/cm² (Body)
- WORKING PRESSURE: 0.5 kgf/cm² ~ 16 kgf/cm²
- WORKING TEMPERATURE: MAX. 220°C

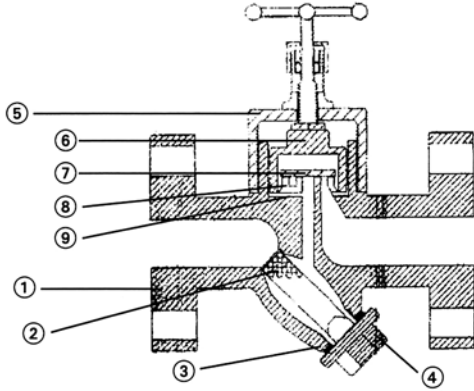

DIMENSIONS							Unit:mm
SIZE	1/2"	3/4"	1"	1 1/4"	1 1/2"	2"	
L	145	163	170	205	205	240	
H	68	75	87	110	110	115	

MATERIALS LIST		
NO.	PART NAME	MATERIAL
1	BODY	CAST IRON
2	SCREEN	S.S.304
3	GASKET	ASBESTOS
4	NUT	CAST IRON
5	BODY CAP	CAST IRON
6	NUT	CAST IRON
7	DISC	AISI 420
8	DRAIN PLUG	S.S.304
9	WASHER	ASBESTOS

KE-8271

STEAM TRAP, SCREWED ENDS(WITH HANDWHEEL)

MATERIAL: CAST IRON

SIZE: 1/2" thru 2"

- TEST PRESSURE: 16 kgf/cm² (Body)
- WORKING PRESSURE: 0.5 kgf/cm² ~ 16 kgf/cm²
- WORKING TEMPERATURE: MAX. 220°C

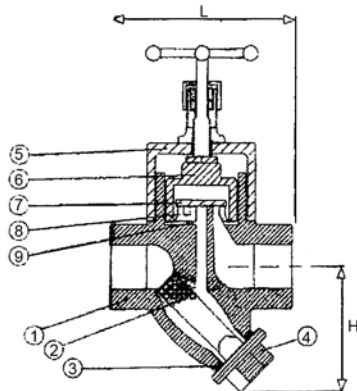

DIMENSIONS							Unit:mm
SIZE	1/2"	3/4"	1"	1 1/4"	1 1/2"	2"	
L	98	105	115	173	173	203	
H	68	75	88	115	115	120	

MATERIALS LIST		
NO.	PART NAME	MATERIAL
1	BODY	CAST IRON
2	SCREEN	S.S.304
3	GASKET	ASBESTOS
4	NUT	CAST IRON
5	BODY CAP	CAST IRON
6	NUT	CAST IRON
7	DISC	AISI 420
8	DRAIN PLUG	S.S.304
9	WASHER	ASBESTOS