

KE-8221F & KE-8321F

INVERTED BUCKET TYPE STEAM TRAP

MATERIAL: ASTM A216. GR. WCB

SIZE: 1/2", 3/4" & 1"

MOP: 69 kg/cm²

TEMPERATURE: 450°C

MAX. DISCHARGE CAPACITY: 430 kg/hr

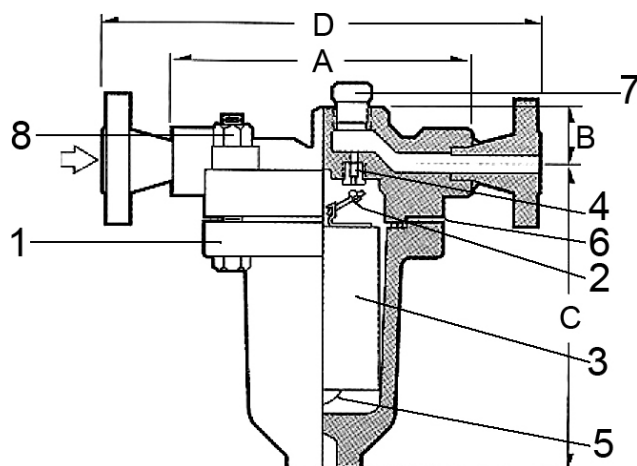

KE-8221F



KE-8321F

MATERIAL LIST

NO.	PART NAME	MATERIAL
1	CAP & BODY	ASTM A216, GR.WCB
2	MECHANISM	STAINLESS STEEL 304
3	BUCKET	STAINLESS W/CAST IRON WT.
4	SEAT & VALVE	HARDENED S.S.440C
5	INLET TUBE	STEEL PIPE
6	GASKET	S.S. 304 W/GRAPHITE
7	BOLTS	ASTM A-193, GR. B7
8	NUTS	ASTM A-194, GR. 2H

DIMENSIONS

DIMENSIONS				Unit:mm
CONN.	A	B	C	D
15.20.25	200	35	298	273

CONTINUOUS DISCHARGE CAPACITY OF CONDENSATION IN KG/HR

Δ P .KG/CM ²	17	230
	20	250
	27	275
	340	300
	41	345
	50	380
	62	410
	69	430

PRESSURE VS TEMPERATURE TRAP BODY RATING

MAX. OPER. PRESSURE SAT. STEAM KG/CM ²	MAX. ALLOWABLE PRESSURE , KG/CM ²		
	340°C	400°C	450°C
69	69	65	50