

# KE-8111A

## Y- TYPE STRAINER, FLANGED ENDS

FLANGED: ANSI 300LB/ JIS 20K

MATERIAL: S.S. 304, S.S. 316 & C.S. WCB

SIZE: 1/2" THRU 10"

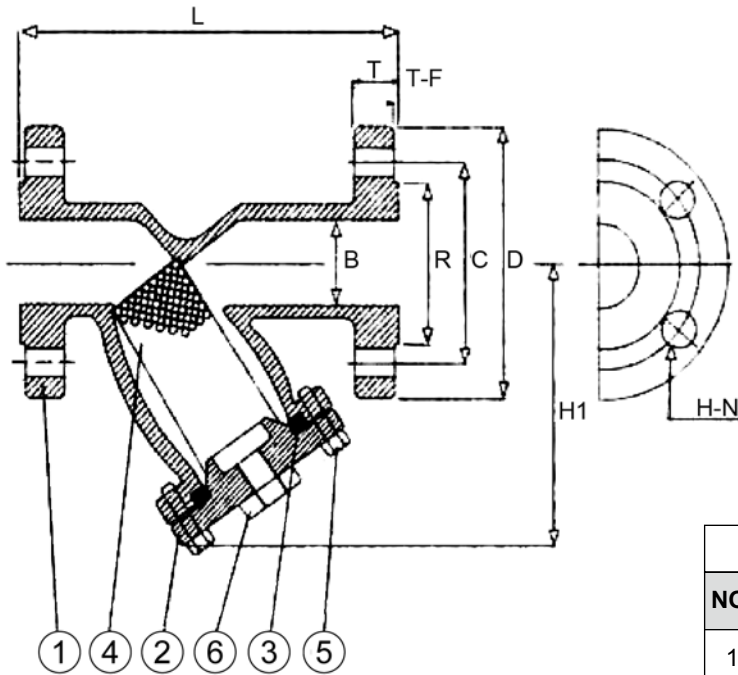

SCREEN SPECIFICATION				
NOMINAL SIZE	PERFORATION	PITCH HOLES	PITCH HOLES	SCREEN THICKNESS
	P	P1	P2	
1/2" TO 2"	1.0	2.5	4	0.4
2-1/2" TO 6"	2.0	3.8	7	0.5
8" AND 10"	3.0	5.5	9	0.6

MATERIAL LIST				
NO.	DESCRIPTION	WCB	CF8	CF8M
1	BODY	A216-WCB	A351-CF8	A351-CF8
2	COVER	A216-WCB	A351-CF8	A351-CF8
3	GASKET	PTFE	PTFE	PTFE
4	SCREEN	SUS 304	SUS 304	SUS 304
5	GLAND BOLT	SS 41	SUS 304	SUS 304
6	DRAIN PLUG	CAST IRON	SUS 316	SUS 316

DIMENSIONS													Unit: mm	
SIZE	Inch	1/2"	3/4"	1"	1 1/2"	2"	2 1/2"	3"	4"	5"	6"	8"	10"	
	mm	15	20	25	32	40	50	65	80	100	125	150	200	
L		140	160	188	193	230	270	320	370	470	500	635	740	
B		15	20	25	40	50	65	80	100	125	150	200	250	
H1		82	91	95	120	145	185	220	250	310	350	430	500	
D	300 LB	95	117	124	156	165	190	210	254	279	318	381	444	
	JIS 20K	95	100	125	140	155	175	200	225	270	305	350	430	
C	300 LB	66.7	82.5	88.9	114.3	127	149.2	168.3	200	234.9	369.9	330.2	387.3	
	JIS 20K	70	75	90	105	120	140	160	185	225	260	305	380	
T	300 LB	14	15	17	20	22	25	28	32	35	37	41	48	
	JIS 20K	14	15	16	18	18	20	22	24	26	28	30	34	
H	300 LB	15	19	19	22	19	22	22	22	22	22	25	29	
	JIS 20K	15	15	19	19	19	19	23	23	25	25	25	27	
n	300 LB	4	4	4	4	8	8	8	8	8	12	12	16	
	JIS 20K	4	4	4	4	8	8	8	8	8	12	12	12	